

BHTS 330°



Łożyska do ekstremalnych temperatur TYLKO DO AUTOMATYCZNEGO SMAROWANIA

6000 SERIA

Oznaczenie	S.we. (B)	S.ze. (D)	S-ość. (W)	Pr-ość. OBR./MIN	Obci.statyc. kN na 330°C	Obci.statyc. kN na 20°C
6000 BHTS 330°	10	26	8	282	1,35	1,96
6001 BHTS 330°	12	28	8	262	1,63	2,36
6002 BHTS 330°	15	32	9	242	1,97	2,85
6003 BHTS 330°	17	35	10	222	2,24	3,25
6004 BHTS 330°	20	42	12	200	3,45	5,00
6005 BHTS 330°	25	47	12	170	4,04	5,85
6006 BHTS 330°	30	55	13	130	5,52	8,00
6007 BHTS 330°	35	62	14	110	7,17	10,4
6008 BHTS 330°	40	68	15	100	8,14	11,8
6009 BHTS 330°	45	75	16	90	9,86	14,3
6010 BHTS 330°	50	80	16	85	10,76	15,6
6011 BHTS 330°	55	90	18	75	14,62	21,2
6012 BHTS 330°	60	95	18	70	16,00	23,2
6013 BHTS 330°	65	100	18	63	17,24	25,0
6014 BHTS 330°	70	110	20	60	21,72	31,5
6015 BHTS 330°	75	115	20	50	23,45	34,0
6016 BHTS 330°	80	125	22	50	27,58	40,0
6017 BHTS 330°	85	130	22	50	29,59	42,9
6018 BHTS 330°	90	140	24	50	34,41	49,9
6019 BHTS 330°	95	145	24	50	37,21	53,9
6020 BHTS 330°	100	150	24	50	37,21	53,9

6200 SERIA

Oznaczenie	S.we. (B)	S.ze. (D)	S-ość. (W)	Pr-ość. OBR./MIN	Obci.statyc. kN na 330°C	Obci.statyc. kN na 20°C
6200 BHTS 330°	10	30	9	262	1,79	2,60
6201 BHTS 330°	12	32	10	242	2,14	3,10
6202 BHTS 330°	15	35	11	180	2,59	3,75
6203 BHTS 330°	17	40	12	175	3,28	4,75
6204 BHTS 330°	20	47	14	150	4,52	6,55
6205 BHTS 330°	25	52	15	140	5,52	8,00
6206 BHTS 330°	30	62	16	110	7,72	11,2
6207 BHTS 330°	35	72	17	100	10,55	15,3
6208 BHTS 330°	40	80	18	85	12,41	18,0
6209 BHTS 330°	45	85	19	80	14,06	20,4
6210 BHTS 330°	50	90	20	75	16,55	24,0
6211 BHTS 330°	55	100	21	67	20,00	29,0
6212 BHTS 330°	60	110	22	60	24,83	36,0
6213 BHTS 330°	65	120	23	53	28,62	41,5
6214 BHTS 330°	70	125	24	50	30,35	44,0
6215 BHTS 330°	75	130	25	50	33,79	49,0
6216 BHTS 330°	80	140	26	50	37,93	55,0
6217 BHTS 330°	85	150	28	50	44,14	64,0
6218 BHTS 330°	90	160	30	50	50,69	73,5
6219 BHTS 330°	95	170	32	50	56,21	81,5
6220 BHTS 330°	100	180	34	50	64,14	93,0

6300 SERIA

Oznaczenie	S.we. (B)	S.ze. (D)	S-ość. (W)	Pr-ość. OBR./MIN	Obci.statyc. kN na 330°C	Obci.statyc. kN na 20°C
6300 BHTS 330°	10	35	11	220	2,38	3,45
6301 BHTS 330°	12	37	12	200	2,86	4,15
6302 BHTS 330°	15	42	13	180	3,72	5,40
6303 BHTS 330°	17	47	14	160	4,52	6,55
6304 BHTS 330°	20	52	15	140	5,86	8,50
6305 BHTS 330°	25	62	17	110	7,86	11,4
6306 BHTS 330°	30	72	19	95	11,24	16,3
6307 BHTS 330°	35	80	21	85	13,10	19,0
6308 BHTS 330°	40	90	23	75	17,24	25,0
6309 BHTS 330°	45	100	25	67	22,06	32,0
6310 BHTS 330°	50	110	27	60	26,21	38,0
6311 BHTS 330°	55	120	29	53	32,76	47,5
6312 BHTS 330°	60	130	31	50	35,86	52,0
6313 BHTS 330°	65	140	33	50	41,38	60,0
6314 BHTS 330°	70	150	35	50	46,90	68,0
6315 BHTS 330°	75	160	37	50	52,76	76,5
6316 BHTS 330°	80	170	39	50	59,66	86,5
6317 BHTS 330°	85	180	41	50	66,55	96,5
6318 BHTS 330°	90	190	43	50	74,48	108
6319 BHTS 330°	95	200	45	50	81,38	118
6320 BHTS 330°	100	215	47	50	96,55	140

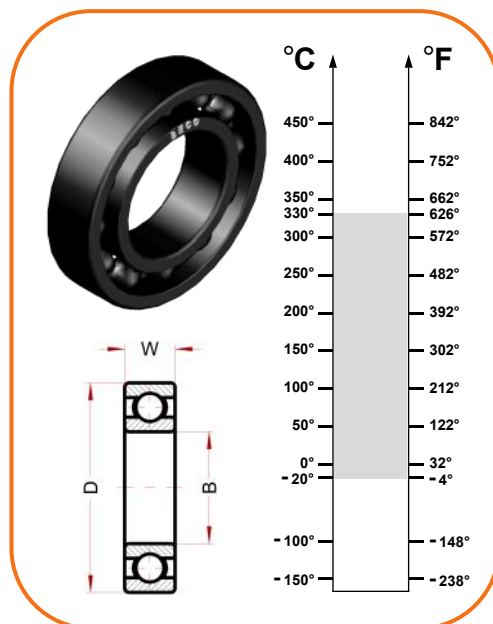

Charakterystyka techniczna:

- **Materiał łożyska:** stal AISI 52100 (Stal chromowa) stabilizowana cieplnie
- **Pokrycie powłoką fosforanu manganu** wszystkich elementów łożyska
- **Luz promieniowy 4xCS**
- **Łożyska pracują otwarte**
- **Smarowanie smarem z dwusiarczkiem molibdenu***
- **Łożyska wymagają dodatkowego dosmarowania olejem przy pracy w wysokich temperaturach**

Uwaga:

*Łożyska smarowane smarem molibdenowym, wymagają dodawania oleju dla wysokich temperatur. Brak okresowego dosmarowywania powoduje szybkie utlenianie i znaczącą redukcję żywotności. Jego stosowanie sugerowane jest tylko w aplikacjach z automatycznym systemem upuszczania oleju.

BECCO

12100 Cuneo - Italy
phone: 0039 0171 66883
mail: office@becoitalia.biz
www.becoitalia.biz



in Poland