

# BHTS 2RS C4 VT 220°

## Łożyska wysokotemperaturowe



6000 SERIA

Oznaczenie	S.we. (B)	S.ze. (D)	S-ość. (W)	Pr-ość. OBR./MIN	Obci.statyc. kN na 220°C	Obci.statyc. kN na 20°C
6000 BHTS 2RS C4 VT 220°	10	26	8	4200	1,50	1,96
6001 BHTS 2RS C4 VT 220°	12	28	8	4060	1,79	2,36
6002 BHTS 2RS C4 VT 220°	15	32	9	3920	2,13	2,85
6003 BHTS 2RS C4 VT 220°	17	35	10	3780	2,46	3,25
6004 BHTS 2RS C4 VT 220°	20	42	12	3640	3,83	5,00
6005 BHTS 2RS C4 VT 220°	25	47	12	3360	4,42	5,85
6006 BHTS 2RS C4 VT 220°	30	55	13	3080	6,11	8,00
6007 BHTS 2RS C4 VT 220°	35	62	14	2800	7,91	10,4
6008 BHTS 2RS C4 VT 220°	40	68	15	2520	9,01	11,8
6009 BHTS 2RS C4 VT 220°	45	75	16	2240	10,8	14,3
6010 BHTS 2RS C4 VT 220°	50	80	16	1960	11,9	15,6
6011 BHTS 2RS C4 VT 220°	55	90	18	1680	16,1	21,2
6012 BHTS 2RS C4 VT 220°	60	95	18	1400	17,1	23,2
6013 BHTS 2RS C4 VT 220°	65	100	18	1260	18,1	25,0
6014 BHTS 2RS C4 VT 220°	70	110	20	1120	22,8	31,5
6015 BHTS 2RS C4 VT 220°	75	115	20	980	24,0	34,0
6016 BHTS 2RS C4 VT 220°	80	125	22	840	28,8	40,0
6017 BHTS 2RS C4 VT 220°	85	130	22	700	30,9	42,9
6018 BHTS 2RS C4 VT 220°	90	140	24	630	36,0	49,9
6019 BHTS 2RS C4 VT 220°	95	145	24	560	38,8	53,9
6020 BHTS 2RS C4 VT 220°	100	160	24	490	38,8	53,9

6200 SERIA

Oznaczenie	S.we. (B)	S.ze. (D)	S-ość. (W)	Pr-ość. OBR./MIN	Obci.statyc. kN na 220°C	Obci.statyc. kN na 20°C
6200 BHTS 2RS C4 VT 220°	10	30	9	4060	1,96	2,60
6201 BHTS 2RS C4 VT 220°	12	32	10	3920	2,38	3,10
6202 BHTS 2RS C4 VT 220°	15	35	11	3780	2,81	3,75
6203 BHTS 2RS C4 VT 220°	17	40	12	3640	3,57	4,75
6204 BHTS 2RS C4 VT 220°	20	47	14	3360	5,02	6,55
6205 BHTS 2RS C4 VT 220°	25	52	15	3080	6,12	8,00
6206 BHTS 2RS C4 VT 220°	30	62	16	2800	8,50	11,2
6207 BHTS 2RS C4 VT 220°	35	72	17	2520	11,6	15,3
6208 BHTS 2RS C4 VT 220°	40	80	18	2240	13,7	18,0
6209 BHTS 2RS C4 VT 220°	45	85	19	1960	15,5	20,4
6210 BHTS 2RS C4 VT 220°	50	90	20	1680	18,3	24,0
6211 BHTS 2RS C4 VT 220°	55	100	21	1400	22,1	29,0
6212 BHTS 2RS C4 VT 220°	60	110	22	1260	27,5	36,0
6213 BHTS 2RS C4 VT 220°	65	120	23	1120	31,7	41,5
6214 BHTS 2RS C4 VT 220°	70	125	24	980	33,6	44,0
6215 BHTS 2RS C4 VT 220°	75	130	25	840	37,4	49,0
6216 BHTS 2RS C4 VT 220°	80	140	26	700	42,3	55,0
6217 BHTS 2RS C4 VT 220°	85	150	28	630	49,2	64,0
6218 BHTS 2RS C4 VT 220°	90	160	30	560	56,5	73,5
6219 BHTS 2RS C4 VT 220°	95	170	32	490	62,7	81,5
6220 BHTS 2RS C4 VT 220°	100	180	34	420	71,5	93,0

6300 SERIA

Oznaczenie	S.we. (B)	S.ze. (D)	S-ość. (W)	Pr-ość. OBR./MIN	Obci.statyc. kN na 220°C	Obci.statyc. kN na 20°C
6300 BHTS 2RS C4 VT 220°	10	35	11	3920	2,64	3,45
6301 BHTS 2RS C4 VT 220°	12	37	12	3780	3,15	4,15
6302 BHTS 2RS C4 VT 220°	15	42	13	3640	4,08	5,40
6303 BHTS 2RS C4 VT 220°	17	47	14	3360	4,93	6,55
6304 BHTS 2RS C4 VT 220°	20	52	15	3080	6,40	8,50
6305 BHTS 2RS C4 VT 220°	25	62	17	2800	8,67	11,4
6306 BHTS 2RS C4 VT 220°	30	72	19	2520	12,5	16,3
6307 BHTS 2RS C4 VT 220°	35	80	21	2240	14,5	19,0
6308 BHTS 2RS C4 VT 220°	40	90	23	1960	19,1	25,0
6309 BHTS 2RS C4 VT 220°	45	100	25	1680	24,5	32,0
6310 BHTS 2RS C4 VT 220°	50	110	27	1400	29,1	38,0
6311 BHTS 2RS C4 VT 220°	55	120	29	1260	36,3	47,5
6312 BHTS 2RS C4 VT 220°	60	130	31	1120	39,8	52,0
6313 BHTS 2RS C4 VT 220°	65	140	33	980	45,9	60,0
6314 BHTS 2RS C4 VT 220°	70	150	35	840	52,0	68,0
6315 BHTS 2RS C4 VT 220°	75	160	37	700	58,5	76,5
6316 BHTS 2RS C4 VT 220°	80	170	39	630	66,5	86,5
6317 BHTS 2RS C4 VT 220°	85	180	41	560	74,2	96,5
6318 BHTS 2RS C4 VT 220°	90	190	43	490	83,1	108
6319 BHTS 2RS C4 VT 220°	95	200	45	420	90,7	118
6320 BHTS 2RS C4 VT 220°	100	215	47	350	107,7	140

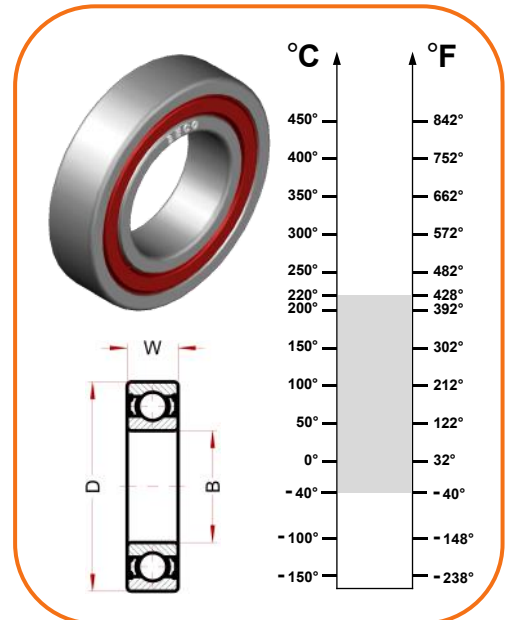

### Charakterystyka techniczna:

- Materiał łożyska: stal AISI 52100 (Stal chromowa) stabilizowana cieplnie
- Luz promieniowy C4
- Uszczelnienie 2RS, stalowa blaszka zwulkanizowana z Vitonu do 250°C
- Nasmarowane dożywno smarem bazującym na teflonie PTFE wolny od silikonu dla temperatury do 280°C
- Smar dopuszczony do przemysłu spożywczego
- Nie wymaga dodatkowego smarowania

### Zastosowanie:

- Przenośniki powietrzne
- Wentylatory przemysłowe
- Maszyny pakujące
- Przemysł stalowy
- Przemysł ceramiczny
- Przemysł papierniczy

# BECCO

12100 Cuneo - Italy  
 phone: 0039 0171 66883  
 mail: office@becoitalia.biz  
 www.becoitalia.biz



in Poland